

Set Components

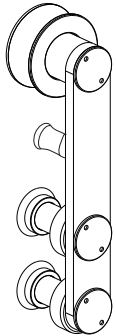

Face Mounted Roller
(x2)

Note: Roller Design will vary based on the Series

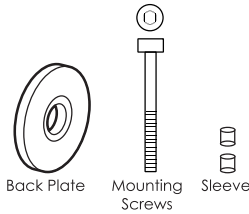

Mounting Accessories Kit
(Quantity: See Chart)

24 3/4" (628.5mm)



End Rail

(Quantity: see chart)

22 33/64" (571.5mm)



Center Rail

(Quantity: see chart)

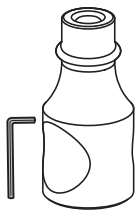

Door Stop
(x2)

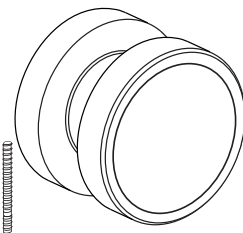

Flush door handle
(x1)

24" (609.5mm)

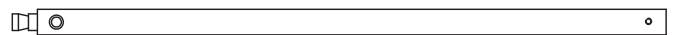

Extense Rail

(Quantity: see chart)

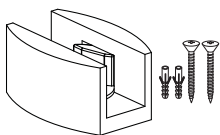

Floor guide
(x1)



Pin Tool
(Tool required on selected items only)

Rail Size	End Rail	Center Rail	Extense Rail	Mounting Accessories
6 FT	2	1	0	4
8 FT	2	1	1	5
10 FT	2	1	2	6
12 FT	2	1	3	7
14 FT	2	1	4	8
16 FT	2	1	5	9
18 FT	2	1	6	10
20 FT	2	1	7	11

You need

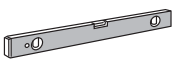

Spirit Level

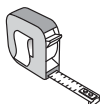

Measuring Tape



Pencil



Power Drill

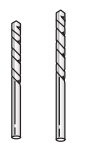

Drill Bit
5/16" [8 mm]
25/64" [10 mm]

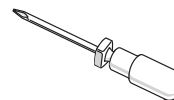

Phillips Screwdriver

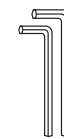

Metric Alley Key Set

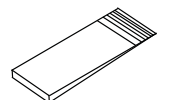

Plastic Wedge or Wood Shim

Steps

Note: It is the sole responsibility of the purchaser to provide adequate door to accommodate the loading capacity of the rail system.

All technical advice is subject to alteration based on the job condition.

1

Drill first hole

Drill first hole for exterior fastening of rail on wall according to detailed drawing.

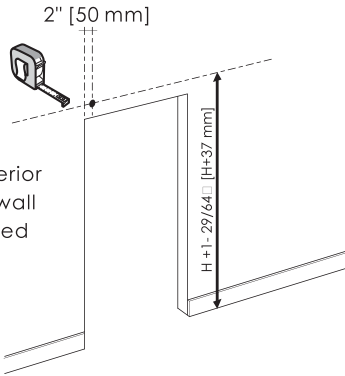

2

Drill remaining mounting holes

"Loosely" screw on the exterior end of the rail. Using the level, ensure the rail will be horizontally straight and use it as a drilling jig to pre-drill the fastening holes with an 5/16" [8 mm] drill bit. Drill the holes for the screw anchors with a 25/64" [10 mm] drill bit.

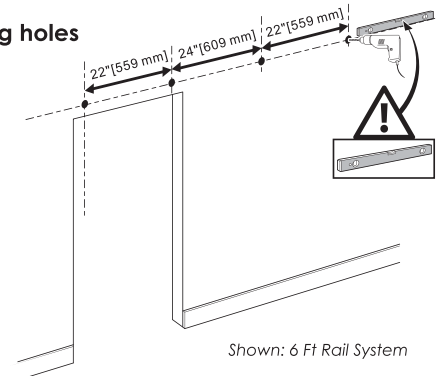

3

Fasten Rail Connector

Join both extremities of the rails, align the set screw to be tighten later



4

Install Door Stops to Rail

Adjust stops accordingly. Tighten top set screw with sufficient force to drive set screw into rail after final adjustment.

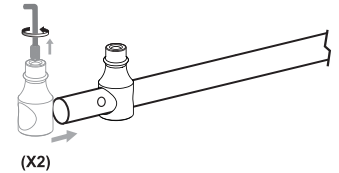

5

Mount Rail to the Wall

Fasten both extremities of the rail on the wall with the back plate and sleeve using the enclosed fastening devices.

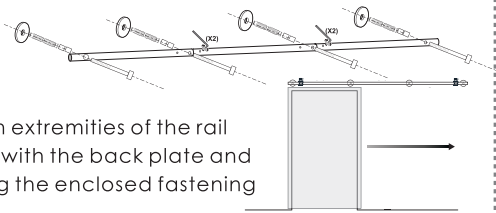

6

Attach Floor Guide

Plum the door and mark for position of floor guide. Fasten the floor guide using the enclosed screws to the floor. The door leaf should run parallel to the wall.

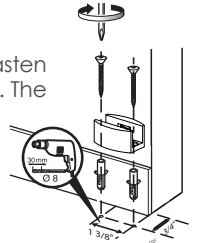

7

Attach Roller to the Top of the Door

Before installing the door roller be sure to outline the correct position and pre-drill your holes. Fasten the door roller to your door using the enclosed screws. Tighten the screws by hand.

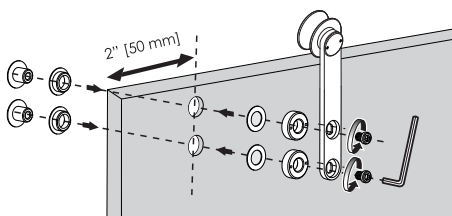

8

Attach the handle

Create a opening into your door panel of 2" [50 mm] diameter. Install the flush round handle to the door simply tightening both ends by hand.

Ø 2" [50 mm] for the flush handle installation

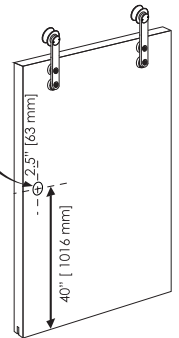

9

Hang the assembled sliding door onto Rail

Remove the Anti-jump pin from the door rollers and carefully hang the assembled sliding door onto the rail. For security purposes place plastic wedges under the sliding door panel insuring 1/4" [7 mm] spacing. Slide the door onto floor guide and ensure the door stops are secure. Remove plastic wedges or wood shims.

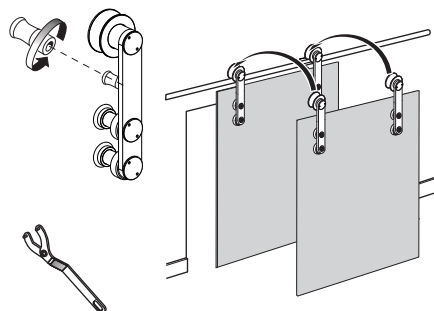

Note: Tool to remove and refasten Safety Pin / Caps will be included based on the Roller Design.

10

Re-fasten Safety Pin

Re-attach the safety pin on the rollers. The safety pin should not be touching the rail.

11

Final Check-UP

Go back and make sure that all screws are installed correctly and re-tighten if needed. Test that the door is sliding properly. Make any necessary adjustments to the stoppers.

FEATURES

- These face mounted door rollers will glide smooth and silent on Nylon-coated wheels so barn doors can be maneuvered effortlessly.
- Suitable for glass doors with a loading capacity of 220 lbs.
- Each roller is equipped with an anti-jump pin that will eliminate the risk of your door shifting or coming off the track, rendering your space safe for all.
- Entirely made of 304 grade Stainless Steel

FINISHES AVAILABLES

- Brushed Satin, Polished Chrome, Black Powder

PRODUCT SKU

- SHPL-GRA-GF-01

SPECIFICATIONS

- Material: 304 grade Stainless Steel
- Weight Capacity: 220 Lbs.
- Application: Glass doors
- Min & Max. Door Thickness: 5/16 – 1/2"

DOOR CONFIGURATION

- Single Door, Double Door or Multiple Doors

PERFORMANCE

- Meets requirements for sliding barn doors by exceeding 100,000 cycles in operation

[CONSTRUCTION SPECIFICATIONS INSTITUTE \(CSI\)](#)

- Division 8 – Door and Windows
CSI Code: 08700 – Hardware
CSI Code: 08710 – Door Hardware

INSTALLATION NOTES

- It is the sole responsibility of the purchaser to provide adequate door to accommodate the loading capacity of the rail system.
- All technical advice is subject to alteration based on the job condition.
- Simple to install.

WARRANTY

- One year limited warranty`

These dimensions and specifications are subject to change without notice